

BALL VALVES INTEC

K200, 6" - 8", Class 150/300
with floating ball, soft seated

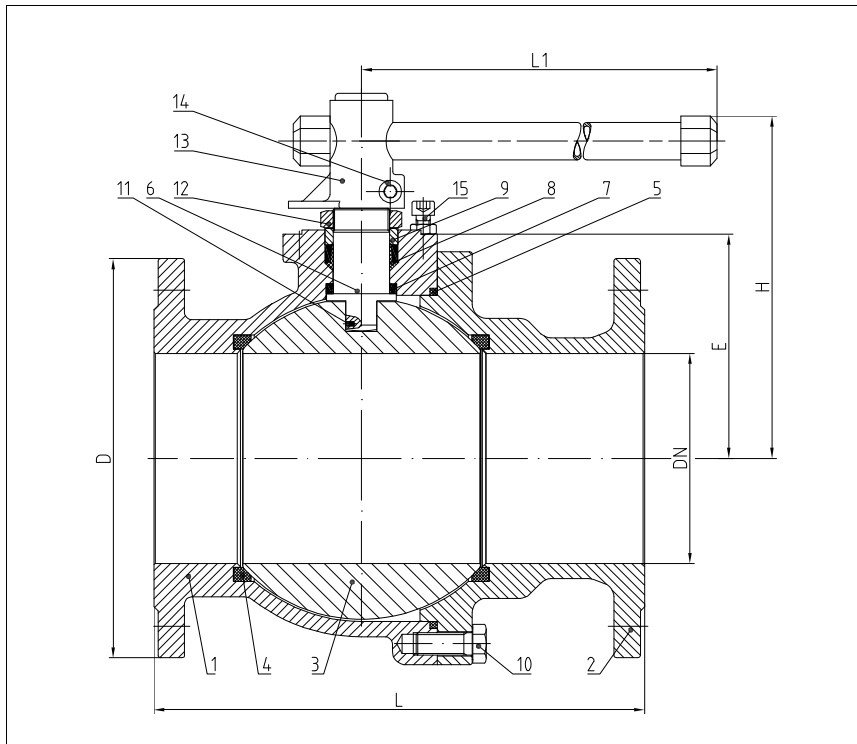

Flanged ball valve
full bore
face to face acc. to ANSI B 16.10
flanges acc. to ANSI B 16.5

Specification:

Two-piece ball valve, flanges acc. to ANSI B 16.5, face to face dimensions acc. to ANSI B 16.10, full bore, blow-out-proof stem, body material stainless steel (ASTM A351-CF8M) or carbon steel (ASTM A216-WCB), antistatic device, free of non ferrous metals, seat full chambered, stem packing Graphite/KFGN/KFAM cone ring system dynamic loaded adjustable, top flange DIN EN ISO 5211, approved by PED, certified acc. to GERMAN clean air act VDI 2440, Fire-Safe acc. to DIN EN ISO 10497, with lever.

Marking: INTEC K200

No.	Part	Material	Material
Standard design			
1	body	A216-WCB	ASTM A351-CF8M
2	cap	A216-WCB	ASTM A351-CF8M
3	ball	1.4408 (ASTM A351-CF8M)	
4	seat	KFGN/KFM	
5	body seal	KF	
6	stem	1.4462 (A479 UNS S31803)	
7	below seal	KFGN/Graphite	
8	upper seal	KFAM/Graphite	
9	bearing	PEEK	
10	hex. screw	A4-70 (A193-B8M)	
11	antistatic element	1.4401 (AISI 316)/1.4571 (AISI 316 Ti)/1.4404 (AISI 316 L)	
12	hex. nut self-locking	A2/1.4301 (AISI 304)	
13	lever	1.4408 (ASTM A351-CF8M)/1.4308 (ASTM A351-CF8)	
14	allen screw	A2-70 (A193-B8)	
15	stopper	1.4301 (AISI 304)	
Fire-Safe design			
5	combined body seal	KF-Graphite	
	Fire-Safe seal	Graphite	
9	ring	1.4571 (AISI 316 Ti)/1.4404 (AISI 316 L)	
	thrust washer	PEEK	

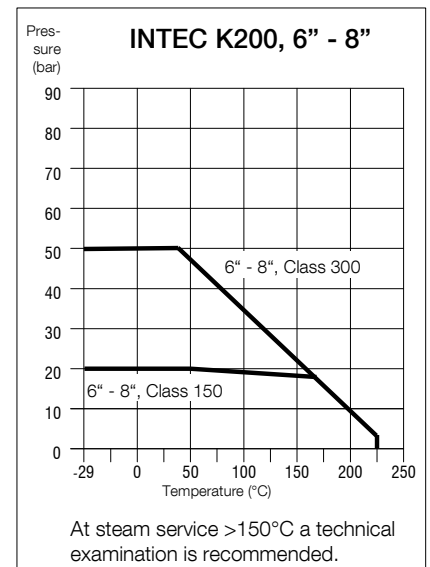

Ordering example:
INTEC K200, 6", Class 300,
CF8M, Fire-Safe

Dimensions

NPS inch	dimensions (mm)		L			D		E	top flange ISO	torque		ca. weight	
	H	L1	150 lbs.	300 lbs.	D	D	Nm* 150 lbs.			Nm* 300 lbs.	kg 150 lbs.	kg 300 lbs.	
6"	280	700	394	403	279	318	181	F12	380	847**	89.0	on request	
8"	340	1000	457	502	343	381	225	F14	742	1731**	145.0	on request	

* Necessary torque measured with treated water at Δ P acc. to pressure class and room temperature.

** Class 300 gearbox recommended.

08/2019

Subject to modification.